

FE-LEEM/PEEM P90 NAP

LOW ENERGY ELECTRON/PHOTOELECTRON EMISSION
MICROSCOPE FOR OPERANDO STUDIES UNDER NEAR
AMBIENT PRESSURE CONDITIONS

KEY FEATURES

- Working pressures from UHV up to Near Ambient Pressure conditions up to 1 mbar
- Sample temperatures up to 1000°C
- Lateral resolution <30 nm
- Integrated imaging energy filter
- Cold field emission gun for LEEM

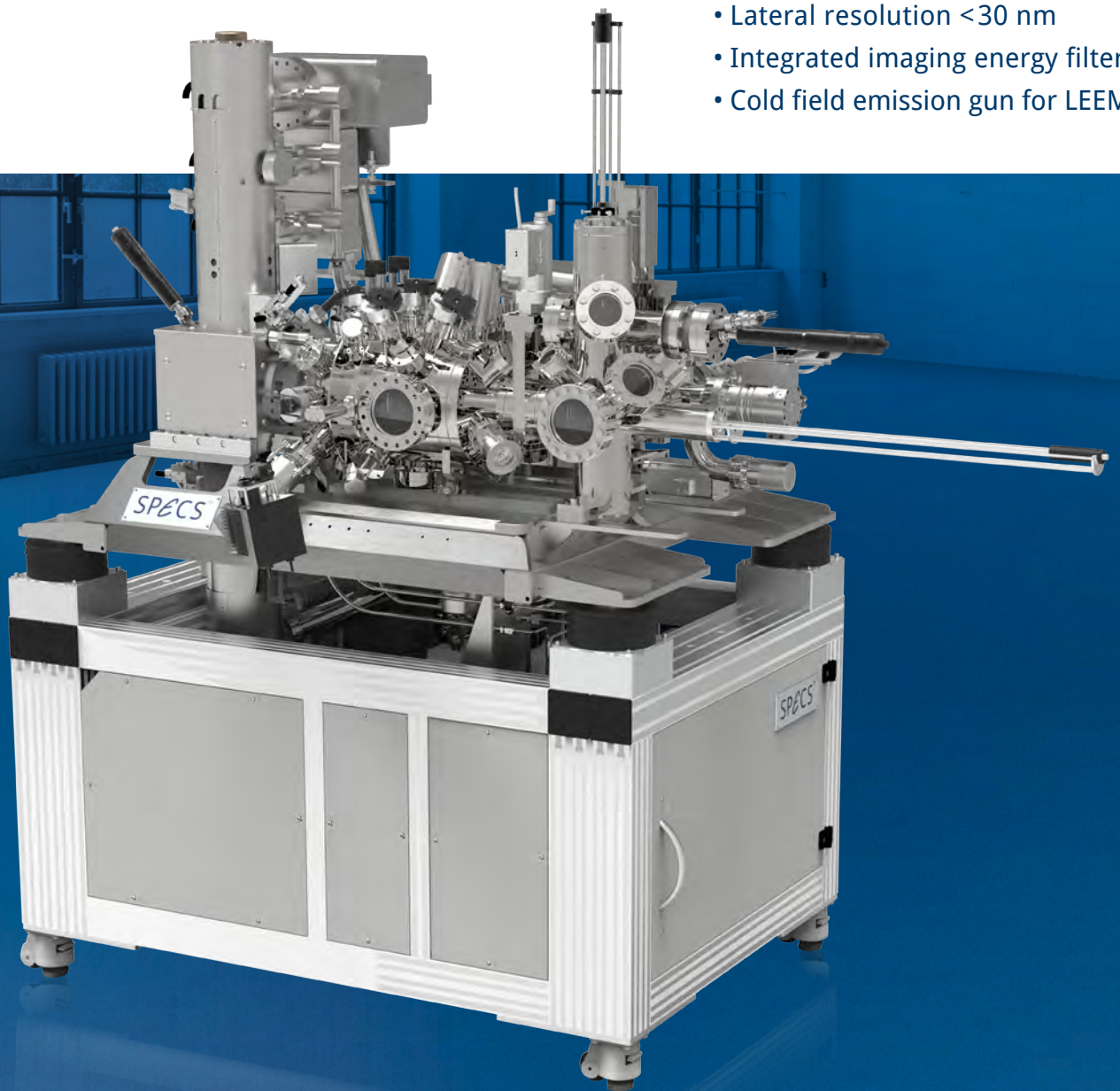

SPECs™

FE-LEEM/PEEM P90 NAP

LOW ENERGY ELECTRON/PHOTOELECTRON EMISSION
MICROSCOPE FOR OPERANDO STUDIES UNDER NEAR
AMBIENT PRESSURE CONDITIONS

The new instrument overcomes the existing limitations to UHV environments by extending the pressure range into the Near Ambient Pressure (NAP) regime.

Introduction

Low Energy Electron Microscopy and Photoelectron Emission Microscopy are the only electron microscopic methods that are really sensitive to the topmost layer of the surface. In combination with the spectroscopic information it is a unique tool for the characterization of dynamic processes at surfaces, like surface reactions. Often the pressure range of standard LEEM/PEEM is not sufficient. Furthermore solid/vapor and liquid/vapor interfaces are omnipresent in nature and the basis for important applications. Thus, investigations at near ambient pressure (NAP) conditions are a key to understanding processes at these interfaces. Analysis techniques like NAP-XPS can work at gas pressures orders of magnitude higher than typical ultra high vacuum conditions. Near Ambient Pressure LEEM and PEEM (NAP-LEEM/PEEM) is the new addition to the tool box, finally allowing for microscopic operando studies under NAP conditions down to the nanoscale.

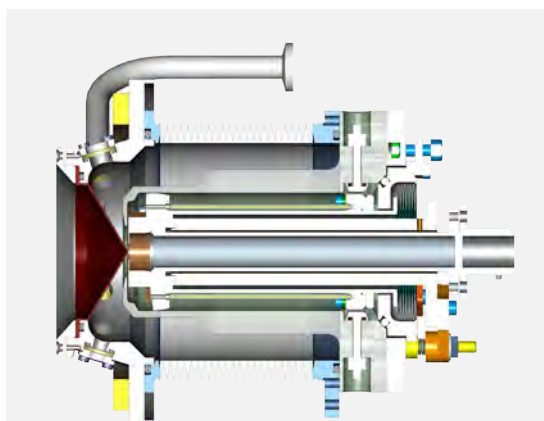

Cross sectional view of the
SPECS FE-LEEM/PEEM P90 NAP gas cell

Technical Concept

The new NAP-LEEM/PEEM is based on the SPECS **FE-LEEM PEEM P90** design. The NAP capability is added by mounting a NAP cell in the sample chamber. The NAP cell enables differential pumping and efficient flow and pressure control. Furthermore the cell design helps minimizing the distance, that electrons need to travel through gas at elevated pressures. As the gas flux out of the cell is limited by the nozzle opening, low pressures can be maintained in the chamber outside the cell. By this, high acceleration voltages can be applied without gas discharge. The nozzle and sample together form an electrostatic immersion lens system, in which the acceleration voltage can be set independently from the column energy for discharge-free operation at elevated gas pressures.

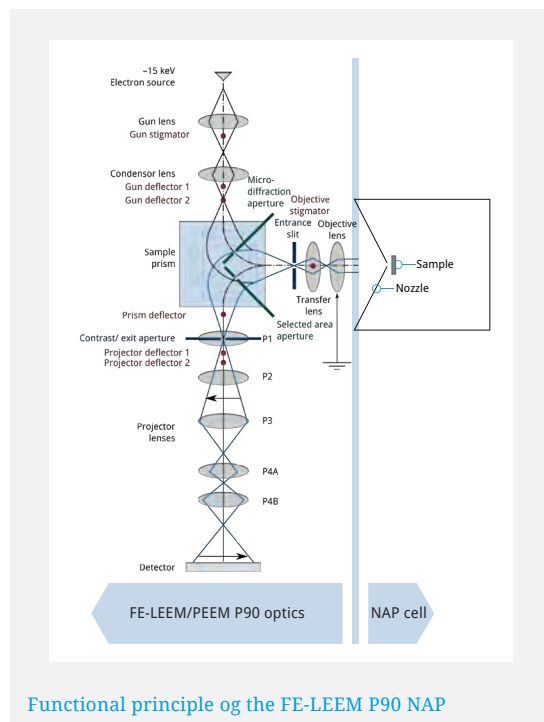

Functional principle of the FE-LEEM P90 NAP

High Resolution Mode

Even in high resolution mode, the FE-LEEM/PEEM P90 NAP enables imaging at gas pressures orders of magnitude higher than typical maximum operating pressures of a UHV instrument. As the nitrogen gas pressure is increased from UHV to 0.1 mbar, the PEEM images shown below get successively darker due to scattering, without an apparent effect on image sharpness.

High Pressure Mode

Above 0.1 mbar it has to be switched to High Pressure Mode. The lateral resolution limit will be about a factor of three lower.

Better than 30 nm at up to 0.1 mbar

LEEM result (in UHV)

PEEM result (at 0.1 mbar)

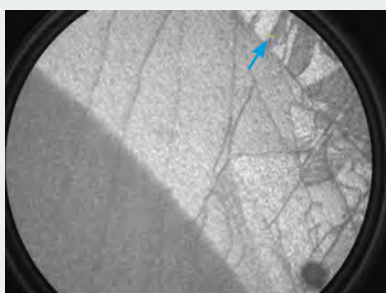

Bright-field LEEM image of MoS₂ on SiO₂ on Si taken (courtesy of J. Jobst). 7 μm field of view

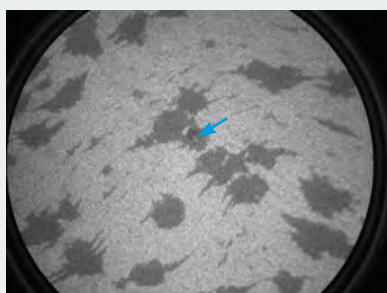

PEEM image of gr/Ru(0001) taken at 0.1 mbar nitrogen gas pressure with a Hg discharge lamp. 14 μm field of view

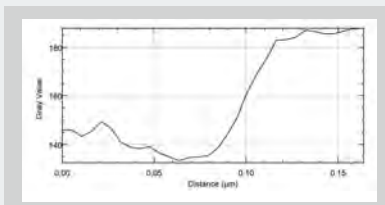

Line profile across the yellow line indicated in the image

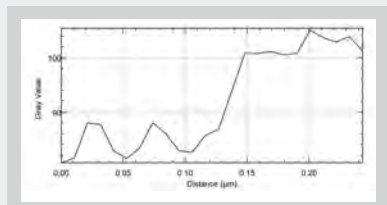

Line profile across the yellow line indicated in the image

Better than 100 nm at 1 mbar

PEEM result (at 1 mbar)

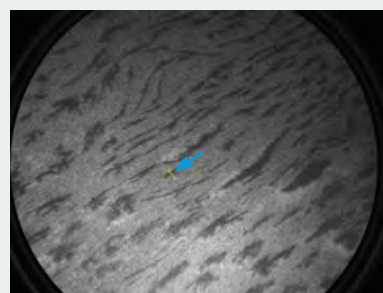

PEEM image of gr/Ru(0001) taken at 1 mbar nitrogen gas pressure with a Hg discharge lamp. 40 μm field of view

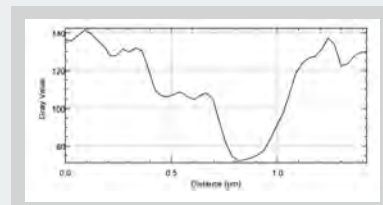

Line profile across the yellow line indicated in the image

Results

An excellent sample to demonstrate operation stability and lateral resolution is Graphene/Ru(0001). The sample has been prepared in the system and transferred to the NAP-cell. A mercury lamp has been used for excitation. Under UHV conditions the imaging parameters for PEEM have been optimized. Then N₂ gas has been introduced up to pressures of 0.1 mbar in High Resolution Mode. After switching to the High Pressure Mode the gas pressure has furtherly been increased to 1.0 mbar.



PEEM on Graphene/Ru(0001)

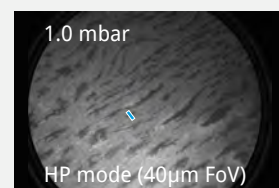
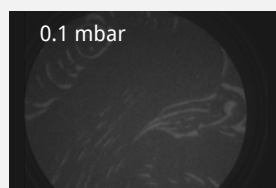
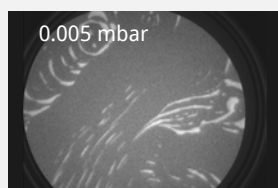

SPECS Surface Nano Analysis GmbH
Voltastrasse 5
13355 Berlin / Germany
www.specs.com

T +49 30 46 78 24-0

F +49 30 46 42 083

E info@specs.com

SPECSTM