

# REFLECTION INTERFACE

- Working Distance of 150 mm
- Designed for 2.0 - 5.0  $\mu\text{m}$  Wavelength
- 1 - 2 mm Collection Spot Size
- SMA-905 Fiber Connector



# THE TECHNOLOGY

## INTERFACE | REFLECTION

NLIR's REFLECTION Interface is an optical system designed to reflect and direct infrared (1.0 – 10.0  $\mu\text{m}$ ) light efficiently. It is used in various applications where reflection-based optical pathways are needed.

It consists of two independent products AURALIS Light Source and SAMPLER Accessory.

Designed to be fiber-coupled with MIDWAVE Spectrometer, this interface allows you to perform reflection

measurements at a 15° angle, from 15 cm distance.

Mounting NLIR's REFLECTION Interface on a stand in your production line allows you to perform reflection measurements at scale, in real time ■



## DETAILS



NLIR's AURALIS Light Source coupled together with NLIR's SAMPLER Accessory for effortless reflection measurement.

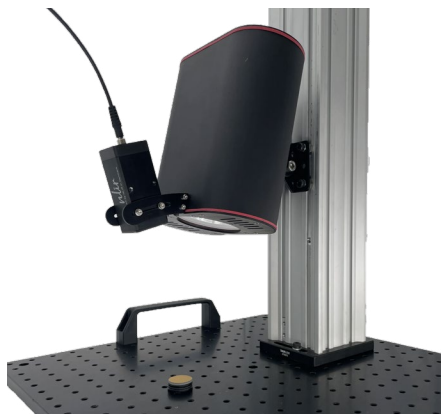

NLIR's AURALIS Light Source illuminates the gold target on the base plate, while the SAMPLER Accessory captures the light reflected from the gold target.

### AURALIS Light Source

Optical Bandwidth	1.0 - 10.0 $\mu\text{m}$
Source	1050 °C Silicon Carbide
Features	Active Power Stabilization
Lifetime <sup>1</sup>	1800 hours
Optical Output	Free-Space
Intensity in Focus Spot	0.5 W/cm <sup>2</sup>
Working Distance	150 mm
Power Consumption	22 - 25 W
Supply Voltage <sup>2</sup>	19 V
Measurements (L × W × H)	180 × 180 × 90 mm
Weight	1.6 kg

### Protective Calcium Fluoride Window

<sup>1</sup> Typical point of time where output start to decrease, source will show end-of-life status

<sup>2</sup> Delivered with the included 19 V supply or an interconnect cable to the MIDWAVE Spectrometer

### SAMPLER Accessory

Optical Bandwidth	2.0 – 5.0 $\mu\text{m}$
Collection Spot Size <sup>1</sup>	1 – 2 mm
Working Distance <sup>2</sup>	146 mm
Optical Output	SMA-905 Fiber Connector
Maximum NA Supported	0.3
Mount Threads	M3 and M4
Measurements (L × W × H)	80 mm × 36 mm × 36 mm
Weight	210 g

<sup>1</sup> Depends on fiber core size

<sup>2</sup> Custom distancing available upon request

# TECH DRAWINGS

## SAMPLER Accessory

FRONT

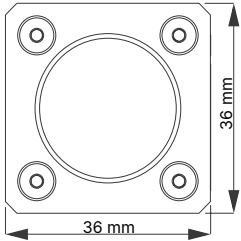

BACK

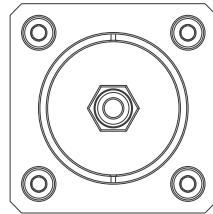

SIDE

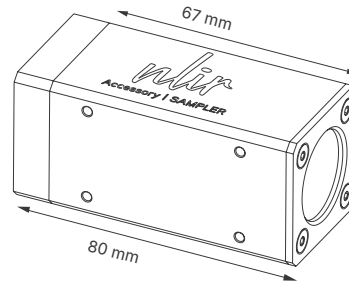

## AURALIS Light Source

FRONT

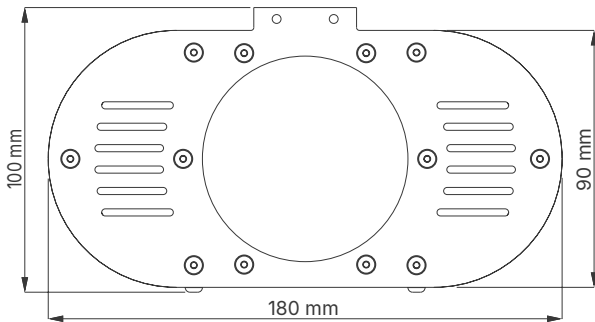

SIDE

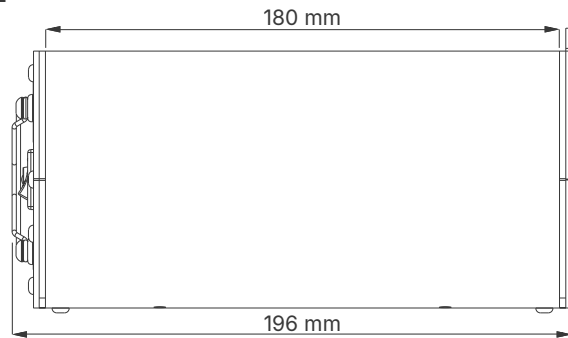

BACK

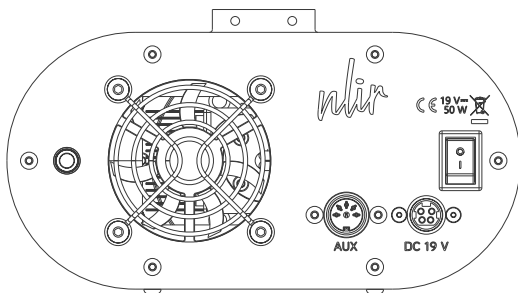

### DESCRIPTION

The drawings provide detailed dimensions and an overview of NLIR's REFLECTION Interface design. It consists of SAMPLER Accessory and AURALIS Light Source. These two devices are connected by a mounting bracket.

NLIR's SAMPLER Accessory is designed for easy mounting with threaded holes on either side. It features M3 and M4 threads,

allowing secure attachment to compatible fixtures or mounts. These threaded holes ensure precise alignment and stable positioning during use, providing flexibility for integration into various optical setups.

NLIR's AURALIS Light Source is equipped with a green LED on the back panel to indicate proper operation. It includes a 19 V DC

power supply input and an AUX port, allowing it to receive power directly from NLIR spectrometers for convenient integration.

On the front panel the optical output is a 3-inch CaF<sub>2</sub> window protecting the user from the hot filament inside the device.

Note that all measurements are in mm ■