

NT252 SERIES

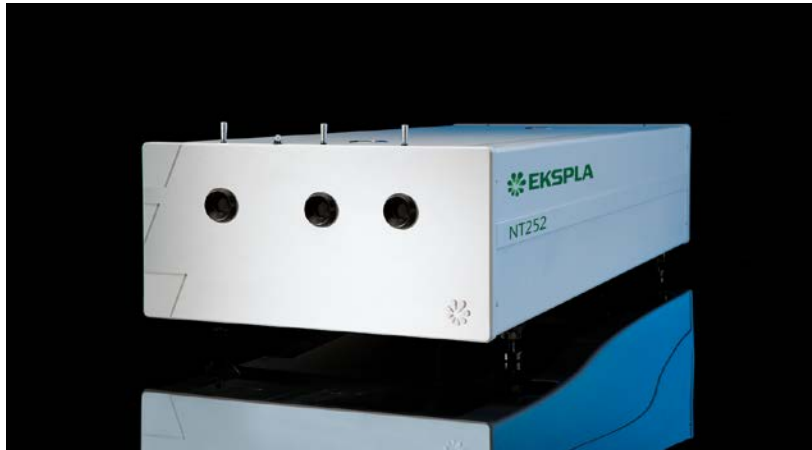

Tunable Wavelength UV-NIR Range DPSS Lasers

FEATURES

- ▶ Integrates DPSS pump laser and OPO into a single housing
- ▶ Dry, no water inside!
- ▶ Hands-free no-gap wavelength tuning from 335 to 2600 nm
- ▶ 1000 Hz pulse repetition rate
- ▶ More than 1.1 mJ output pulse energy in NIR
- ▶ 3–6 ns pulse duration
- ▶ Remote control via key pad or PC

BENEFITS

- ▶ High repetition rate (1000 Hz) enables fast data collection
- ▶ End diode pumping and water-free technology ensure high reliability and low maintenance costs
- ▶ Superior tuning resolution ($1 - 2 \text{ cm}^{-1}$) allows recording of high quality spectra
- ▶ High integration level saves valuable space in the laboratory
- ▶ In-house design and manufacturing of complete systems, including pump lasers, guarantees on-time warranty and post warranty services and spares supply
- ▶ Variety of control interfaces: USB, RS232, LAN and WLAN ensures easy control and integration with other equipment
- ▶ Attenuator and fiber coupling options facilitate incorporation of NT252 systems into various experimental environments

APPLICATIONS

- ▶ Photoacoustic imaging
- ▶ Laser-induced fluorescence spectroscopy
- ▶ Pump-probe spectroscopy
- ▶ Photobiology
- ▶ Remote sensing
- ▶ Metrology

NT252 series tunable laser systems integrates into a single compact housing a nanosecond Optical Parametric Oscillator (OPO) and Diode-Pumped Solid-State (DPSS) Q-switched pump laser.

Diode pumping enables fast data acquisition at high pulse repetition rates up to 1 kHz while avoiding frequent flashlamp changes that are common when flashlamp pumped lasers are used. Special cooling technology eliminates the need for tap water, thus further reducing running and maintenance costs.

All lasers feature motorized tuning across the specified tuning range. The output wavelength can be set from control pad with backlit display that is easy to read even while wearing laser safety glasses. Alternatively, the laser can be also controlled from personal computer using supplied LabVIEW™ drivers.

High conversion efficiency, stable output, easy maintenance and compact size make our systems excellent choice for many applications.

Accessories and Optional Items

Option	Features
-SH	Tuning range extension in UV range (335 – 670 nm) by second harmonic generation
-H, -2H	1064 and 532 nm output via separate port
-FC	Fiber coupler
-Attn	Attenuator option

SPECIFICATIONS ¹⁾

Model		NT252
OPO		
Wavelength range		
Signal		670–1063 nm
Idler		1064–2600 nm
SH		335–670 nm
Pulse energy		
OPO ²⁾		1100 μJ
SH ³⁾		200 μJ
Pulse repetition rate		1000 Hz
Linewidth ⁴⁾		<10 cm ⁻¹
Tuning resolution ⁵⁾		
Signal		1 cm ⁻¹
Idler		1 cm ⁻¹
SH		2 cm ⁻¹
Polarization		
Signal		horizontal
Idler		vertical
SH		horizontal
Typical beam diameter ^{6) 7)}		3 × 6 mm
PUMP LASER		
Pump wavelength ⁸⁾		532 nm
Typical pump pulse energy ⁹⁾		4 mJ
Pulse duration ¹⁰⁾		4 – 6 ns
Pulse energy stability (StdDev)		<2.5 %
PHYSICAL CHARACTERISTICS		
Unit size (W × L × H)		456 × 1040 × 297 mm
Power supply size (W × L × H)		520 × 400 × 300 mm
Umbilical length		2.5 m
OPERATING REQUIREMENTS		
Cooling		air-cooled
Room temperature		18–27 °C
Relative humidity		20–80 % (non-condensing)
Power requirements		100–240 V AC, single phase 50/60 Hz
Power consumption		<1.5 kW
Cleanness of the room		not worse than ISO Class 9

¹⁾ Due to continuous improvement, all specifications are subject to change. Parameters marked typical are illustrative; they are indications of typical performance and will vary with each unit we manufacture. Unless stated otherwise, all specifications are measured at 750 nm and for basic system without options.

²⁾ Measured at maximum in the interval 700 – 750 nm. See tuning curves for typical outputs at other wavelengths.

³⁾ Measured at 400 nm. See tuning curves for typical outputs at other wavelengths.

⁴⁾ In signal and idler range.

⁵⁾ For manual input from PC. When wavelength is controlled from keypad, tuning resolution is 0.1 nm for signal, 1 nm for idler and 0.05 nm for SH.

⁶⁾ Measured at the wavelength indicated in the "Pulse energy" specification row.

⁷⁾ Beam diameter is measured at the 1/e² level at the laser output and can vary depending on the pump pulse energy.

⁸⁾ Separate output port for the 2nd and other harmonic are optional.

⁹⁾ The pump laser pulse energy will be optimized for best OPO performance. The actual pump laser output can vary with each unit we manufacture.

¹⁰⁾ Measured at FWHM level with photodiode featuring 1 ns rise time and 300 MHz bandwidth oscilloscope.



PERFORMANCE

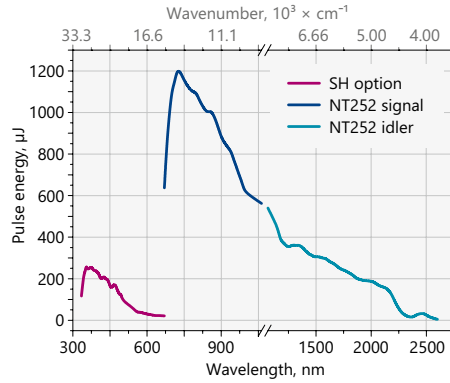

Fig 1. Typical output pulse energy of the NT252-SH tunable laser

OUTLINE DRAWINGS

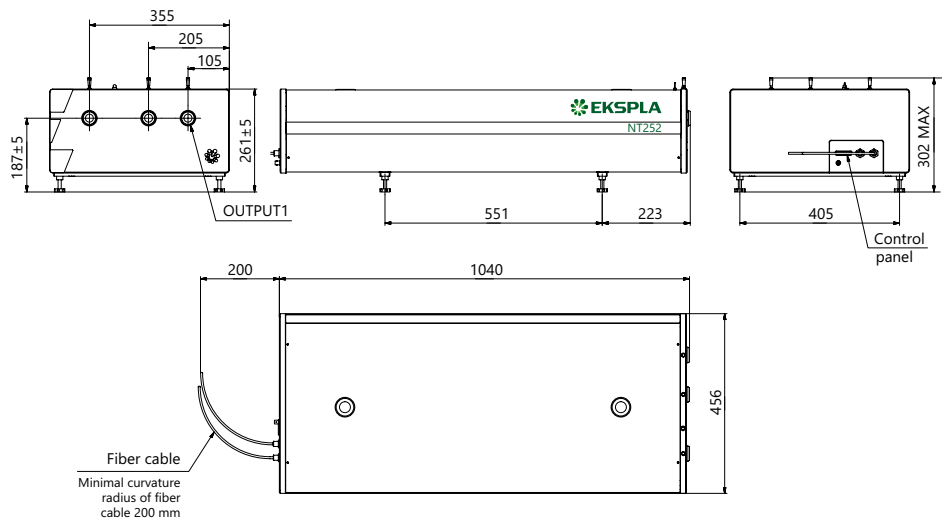
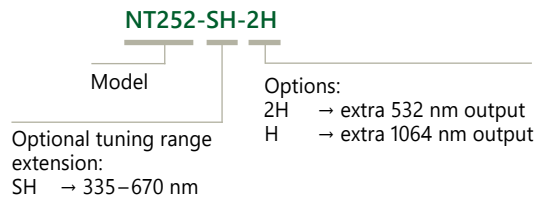

Fig 3. NT252 series laser head dimensions

ORDERING INFORMATION

Note: Laser must be connected to the mains electricity all the time. If there will be no mains electricity for longer than 1 hour then laser (system) needs warm up for a few hours before switching on.



本社：〒134-0088 東京都江戸川区西葛西 6-18-14 T. I. ビル

TEL : 03-3686-4711 FAX : 03-3686-0831

大阪営業所：〒532-0003 大阪市淀川区宮原 4-1-46 新大阪北ビル

TEL : 06-6393-7411 FAX : 06-6393-7055