

SC-05 Standard Cuvette Holder

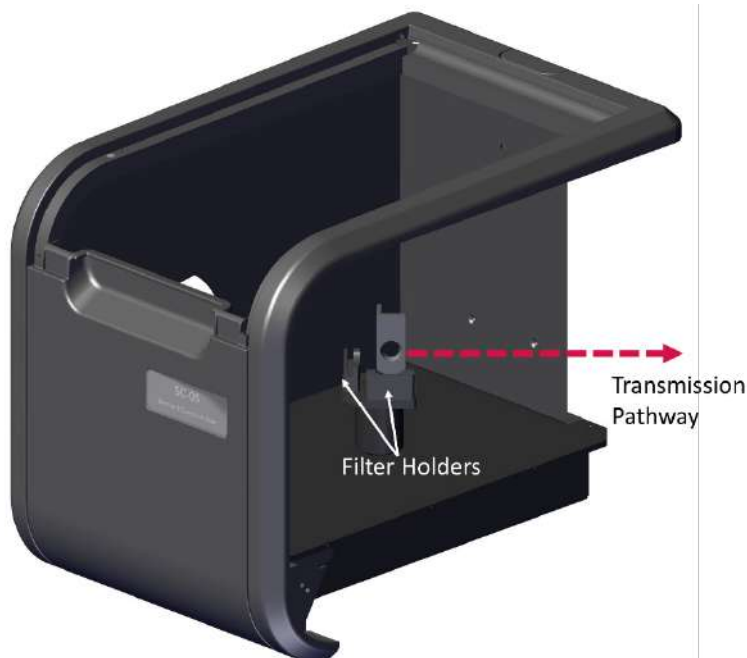

The SC-05 is the standard sample module for the FS5 and is fitted with a cuvette holder for photoluminescence and transmission measurements of liquid samples. The module can also be customised through a range of accessories for the measurement of powders and films. Z height (distance from the base of the cuvette to the beam) is 15 mm.

Features:

- Highly customisable; suitable for a broad range of sample types
- Built-in holders for long pass filters for scattering samples
- Accessories: SCA-1, SCA-2, SCA-3, SCA-6 and SCA-7

Measurement Examples

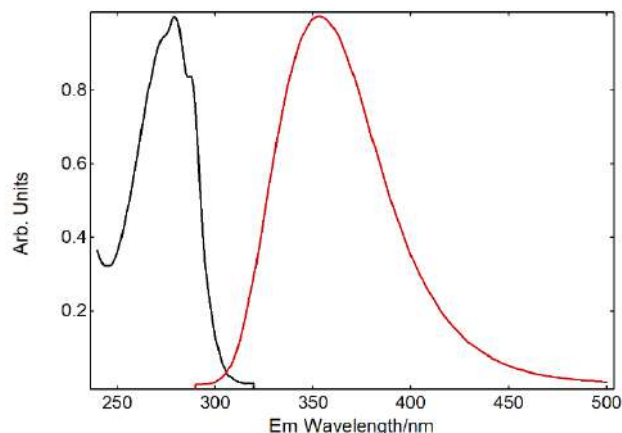
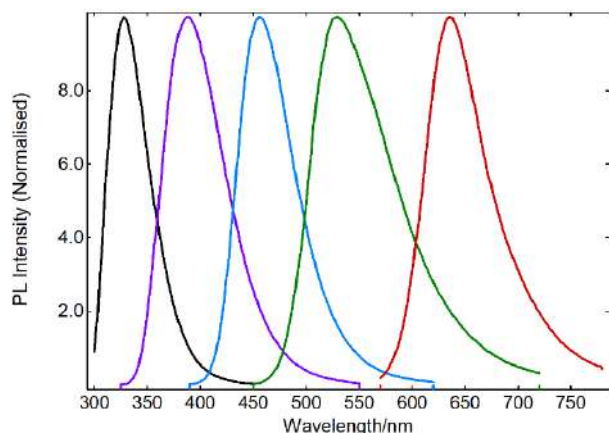

Left: Photoluminescence spectra of fluorescent standards that have been certified by the Bundesanstalt für Materialforschung und -prüfung (BAM). These traceable certified standards are used to ensure the emission calibration of each FS5 is accurate.

Right: Absorbance (black) and emission (red) of NATA in PBS buffer.

SC-06 Two-Position Cuvette Holder

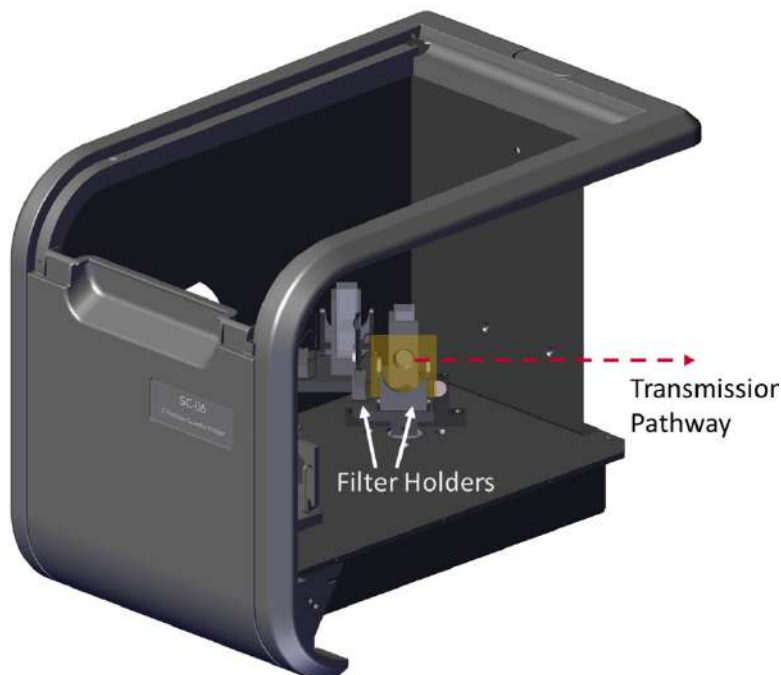

The SC-06 is a two-position cuvette holder for the FS5 which enables automated photoluminescence and transmission measurements of two liquid samples. Fluoracle allows programming different measurements for either sample using batch mode. Automated absorbance measurements are possible by placing the blank solution in one of the cuvettes. Z height (distance from the base of the cuvette to the beam) is 15 mm.

Features:

- Absorption measurement wizard included in software
- Both sample positions have built-in excitation and emission filter holders
- Accessories: SCA-3

Measurement Example

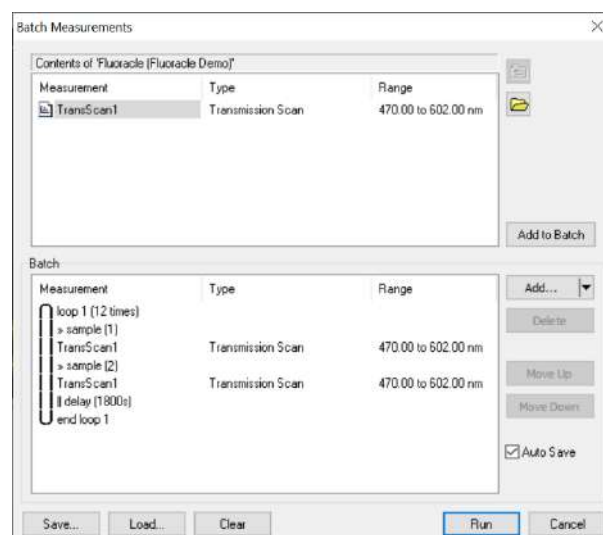
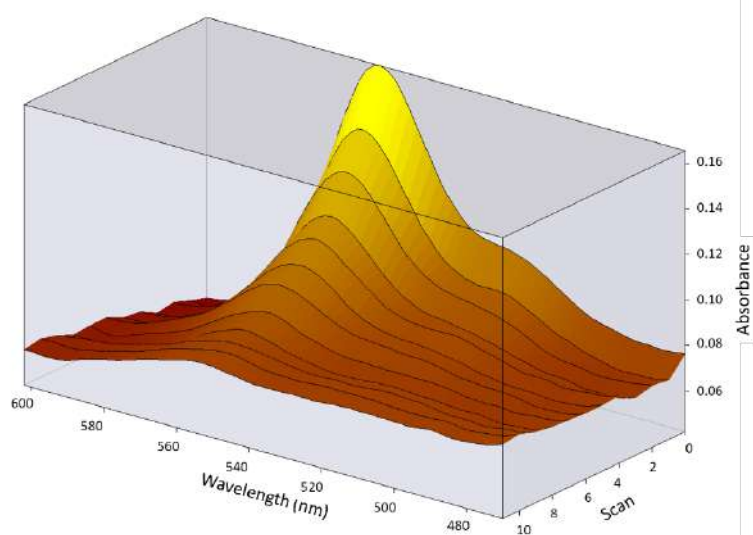

Left: Absorbance spectra of a rhodamine dye solution after addition of NaOCl acquired automatically with SC-06 (30 minutes between spectra).

Right: Batch measurement setup to acquire the data shown on the left.

SC-10 Front-Face Sample Holder – Vertical



The SC-10 sample module is designed for photoluminescence measurements of film and powder samples. The module is also suitable for measuring front-face emission from strongly absorbing solutions.

Features:

- Sample holder is mounted on a linear translation stage that is externally adjustable, allowing accurate sample positioning
- Built-in holders for long pass filters for scattering samples

Sample Holder Inserts

Adjustable screw clamp for holding small crystals or pellet samples

Max. dim.: 10 x 10 mm²

Min. dim.: 2 x 2 mm²



Spring clamp with:

(a) quartz demountable cuvette for powders (35 x 7 x 1 mm³)

(b) quartz slide for planar samples (45 x 12 mm²)



Measurement Examples

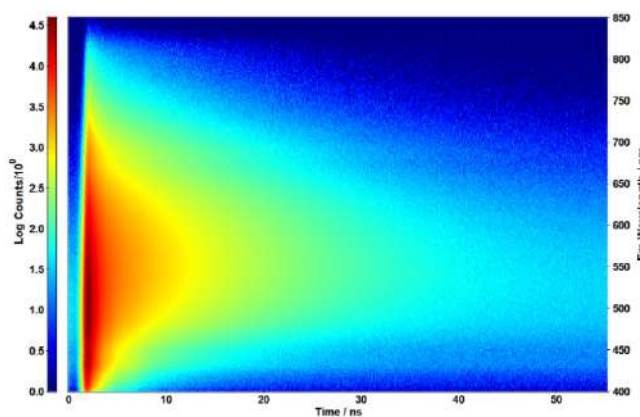
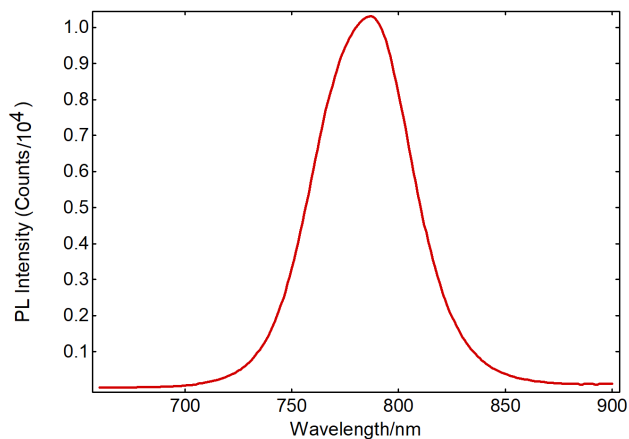

Left: Photoluminescence spectrum of $\text{CH}_3\text{NH}_3\text{PbI}_3$ (MAPI) perovskite thin-film on a quartz substrate, excited above bandgap at 550 nm. **Right:** Time-resolved emission spectrum (TRES) of 2D MAPbBr_3 perovskite powder, excited above bandgap at 375 nm.

SC-15 Front-Face Sample Holder - Horizontal

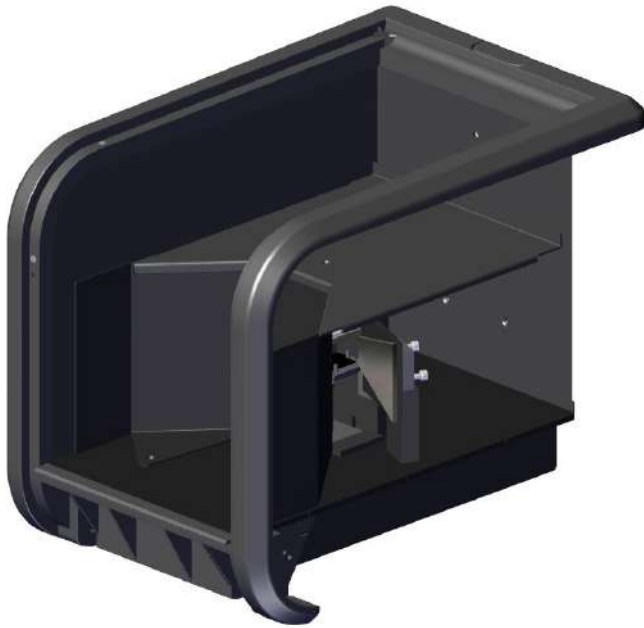

The SC-15 sample module is for powder measurements. The excitation and emission beam paths are redirected into a horizontal powder tray for easier sample loading.

Features:

- Removable powder tray for easy loading of powders.
- Supplied with three powder holders ($\text{\O}12 \times 2 \text{ mm}^3$) which can be quickly swapped
- Built-in holders for long pass filters for scattering samples

Excitation & Emission Configuration

The excitation and emission beam paths are directed vertically towards the horizontal powder tray.

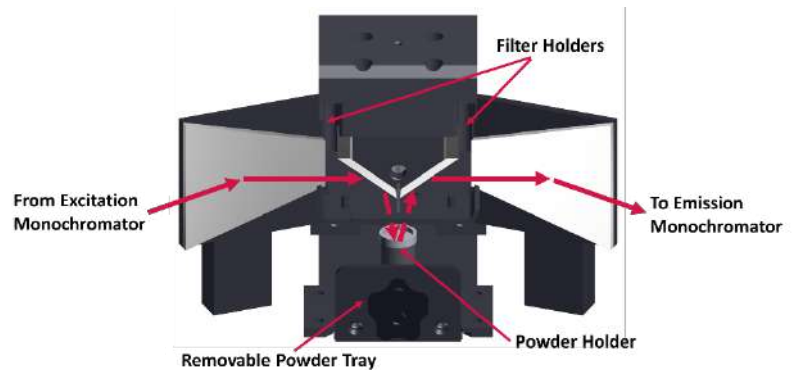

Measurement Examples

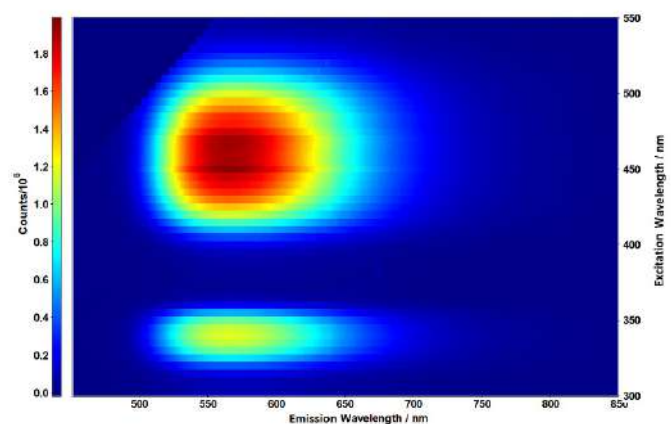
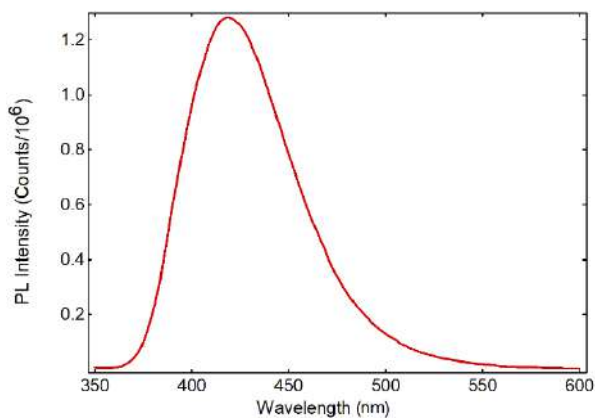

Left: Photoluminescence spectrum of sodium salicylate powder, excited near its absorption maximum at 340 nm. **Right:** Excitation Emission Map (EEM) of a cerium doped YAG phosphor powder.

SC-20 Temperature Controlled Holder – Circulator

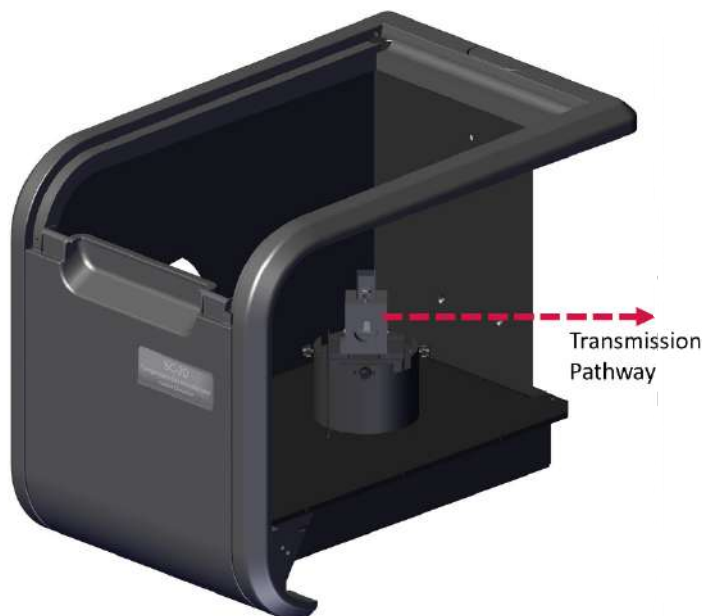

The SC-20 is a temperature-controlled cuvette holder for photoluminescence and transmittance measurements of solutions. The temperature is controlled through an additional external circulator. The module is best suited for maintaining a consistent static temperature such as 37 °C for biological studies. Z height (distance from the base of the cuvette to the beam) is 14 mm.

Features:

- Temperature range*: -10 °C to + 60 °C
- Supplied with 3.5 mm ID tubing
- Built-in magnetic stirrer
- Accessories: SCA-2, SCA-3, SCA-6

Measurement Examples

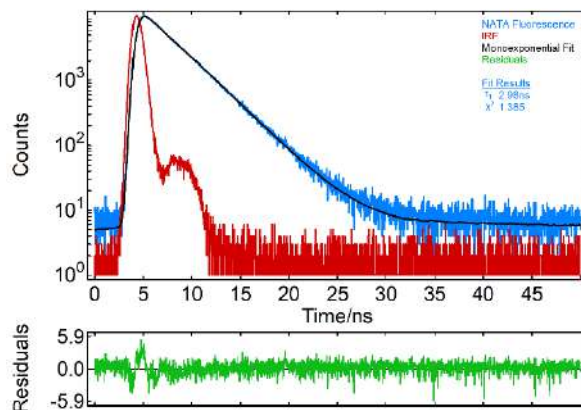
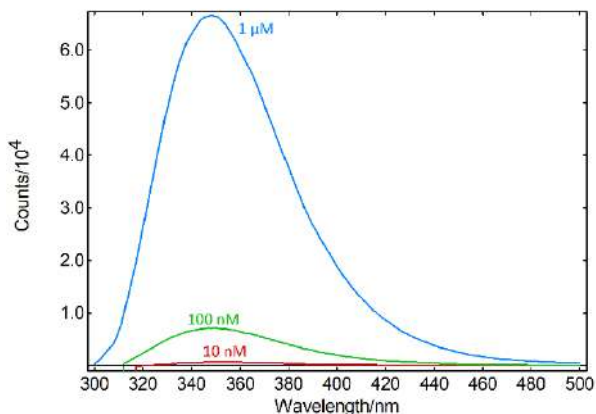

Microvolume fluorescence study of N-Acetyl-L-tryptophanamide (NATA) at 37 °C and pH 7.4.
Left: Fluorescence spectrum of NATA at three concentrations with 700 μ l sample volume.
Right: Fluorescence decays of NATA recorded using TCSPC. The data was fit with a monoexponential using Fluoracle, revealing a lifetime of 3 ns.

Specifications

Temperature Range (°C)*	- 10 to + 60
Temperature Control	Manual (recorded by Fluoracle)
Stirrer Control	Controlled by Fluoracle

*Operation below the dew point (~ 5 °C) requires dry gas purging.

SC-24/25/26 Temperature Controlled Holder – TE Cooled



The SC-24/25/26 are temperature-controlled cuvette holders for photoluminescence and transmittance measurements of solutions. The temperature is fully controllable through the Fluoracle software, which enables variable temperature spectral and lifetime temperature maps to be automatically generated. Z height (distance from the base of the cuvette to the beam) is 15 mm.

Features:

- Temperature range: -50 °C to + 150 °C (model dependent)
- Built-in magnetic stirrer
- Accessories: SCA-2, SCA-3, SCA-6
- Temperature change in batch mode

Measurement Examples

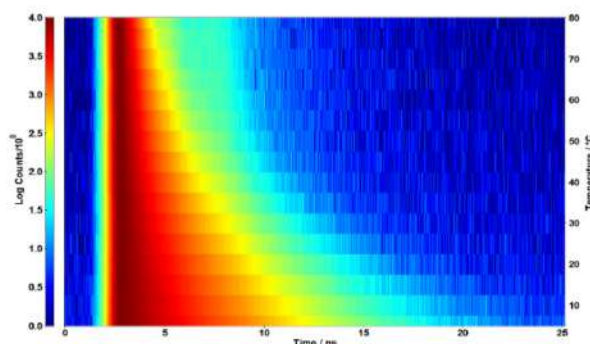
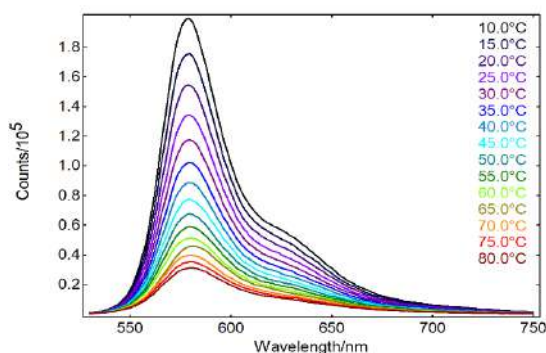

Left: Automatic variable temperature emission scan of Rhodamine-B in H₂O over a temperature range of 10 °C to 80 °C. **Right:** Automatically acquired temperature lifetime map of Rhodamine-B emission in H₂O. The fluorescence lifetime decreases with increasing temperature due to the increasing mobility of the diethylamino groups.

Specifications

Temperature Range (°C)	SC-24*: - 50 °C to +150 °C SC-25*†: -35 °C to +105 °C SC-26*†: -35 °C to +150 °C
Temperature Stability (°C)	± 0.02
Stirrer Control	400 – 4000 RPM
Temperature Control	Automatic (controlled and recorded by Fluoracle)

*Operation below the dew point (~5 °C) requires dry gas purging. †Operation below - 10 °C requires cooled circulating fluid in addition to dry gas purging. Operation below - 20 °C requires a windowed jacket (SCA-4) in addition to cooled circulating fluid and dry gas purging.

SC-27 4-Position Temperature Controlled Holder – TE Cooled

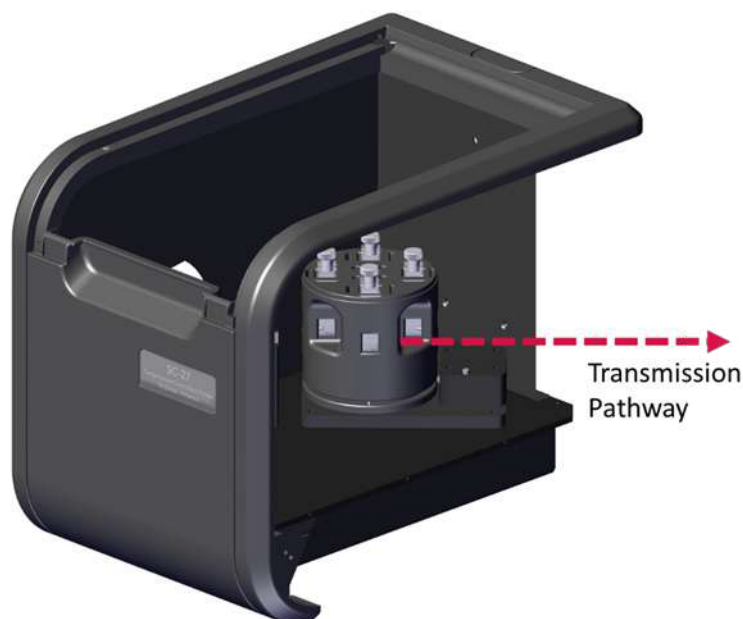

The SC-27 is a four-position temperature-controlled holder for photoluminescence and transmittance of solutions in cuvettes. Spectral and lifetime temperature maps are automatically generated by the Fluoracle software. Sample position is fully software-controlled enabling automated measurements of up to 4 samples. Z height (distance from the cuvette base to the beam) is 15 mm.

Features:

- Built-in magnetic stirrer (same speed in all cuvettes)
- Accessories: SCA-2, SCA-3, SCA-6
- Temperature and sample change in batch mode

Measurement Examples

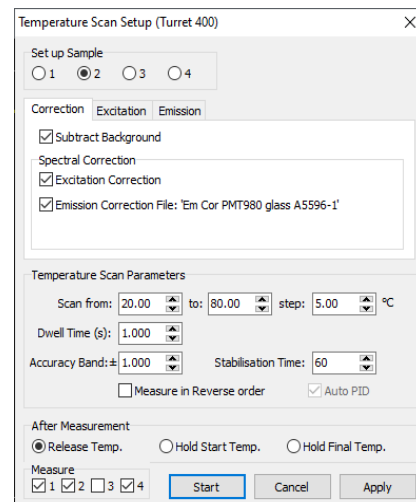
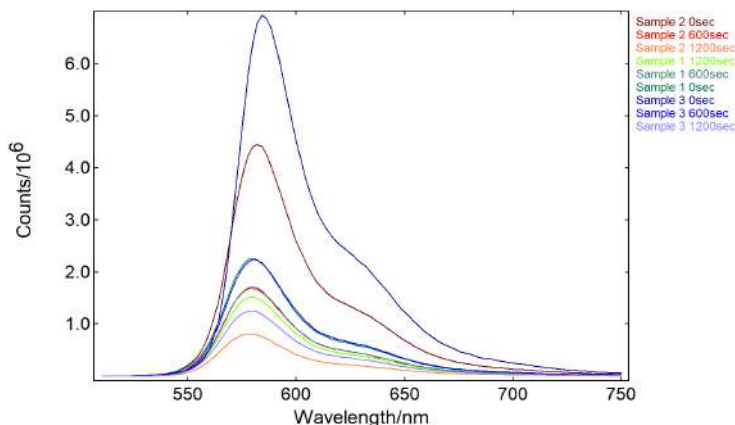

Left: Automatic kinetic emission study of Rhodamine-B emission bleaching at different concentrations, acquired in batch mode. **Right:** Single point temperature scan setup wizard for multiple samples.

Specifications

Temperature Range (°C)*	-40 to +105 (same in all cuvettes)
Temperature Stability (°C)	± 0.02
Stirrer Control	400 – 4000 RPM
Temperature Control	Automatic (controlled and recorded by Fluoracle)

*Operation below the dew point (~5 °C) requires dry gas purging. Operation below - 10 °C requires cooled circulating fluid in addition to dry gas purging. Operation below - 20 °C requires a windowed jacket (SCA-4) in addition to cooled circulating fluid and dry gas purging.

SC-28 Heated Powder Holder

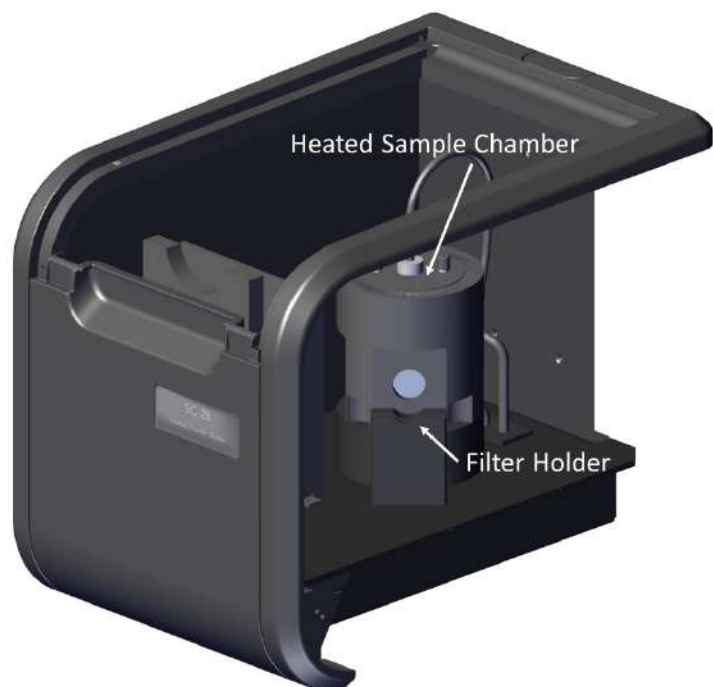

The SC-28 sample module is designed for temperature dependent measurements of solid samples such as powders and thin-films. It is an attractive low-cost alternative to traditional cryostats when sample cooling is not required.

Features:

- High temperature range (30 to 300 °C)
- Built-in holders for long pass filters and feedthroughs and tubing for gas purging

Sample Holder

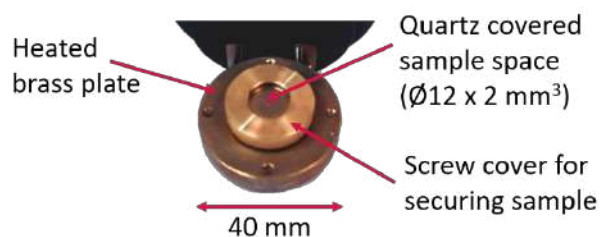

Measurement Examples

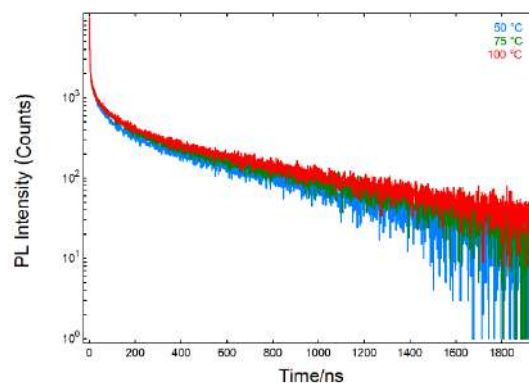
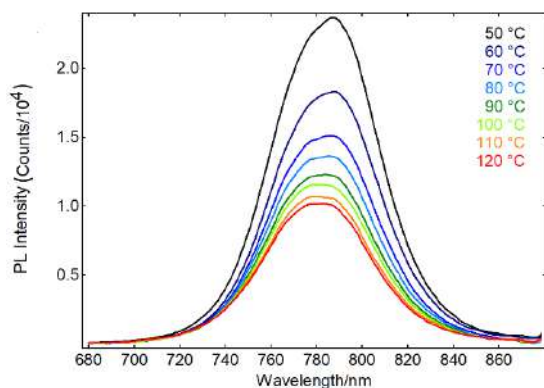

Left: Photoluminescence spectra of $\text{CH}_3\text{NH}_3\text{PbI}_3$ (MAPI) perovskite film excited above bandgap at 550 nm at different temperatures. **Right:** Lifetime spectra of MAPI perovskite film recorded with 480 nm excitation using TCSPC.

Specifications

Temperature Range (°C)*	30 to 300
Temperature Stability (°C)	± 0.3 °C
Temperature Control	Manual (not recorded by Fluoracle)
Sample Holder Volume	Ø12 x 2 mm ³

* The sample module has no active cooling and the minimum temperature is therefore limited to that of the ambient room.

SC-30 Integrating Sphere

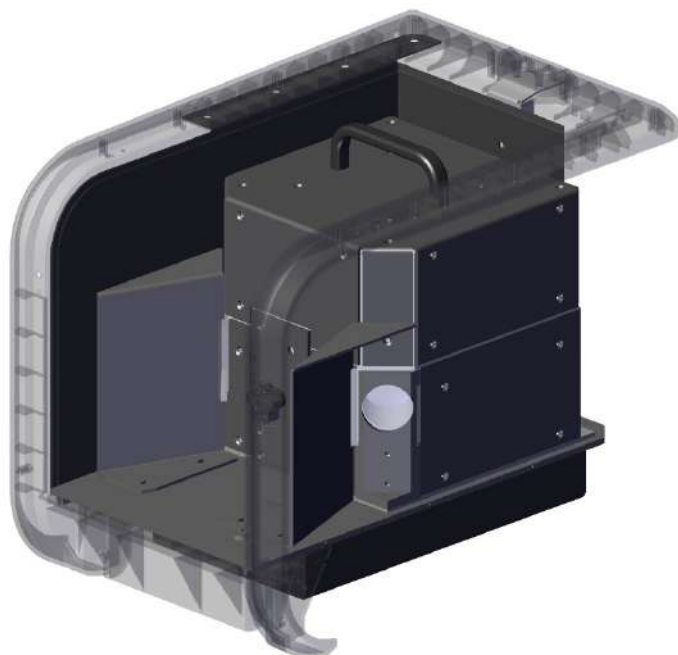

The SC-30 module incorporates a 150 mm diameter integrating sphere for the measurement of absolute quantum yields (QY) and reflectance spectroscopy. The module is suitable for measurements of solutions, films and powders and the QY can be easily calculated using the Fluoracle QY wizard. In addition, the absorbance of scattering samples can be measured using reflectance.

Features:

- Simple QY calculation using the inbuilt software wizard
- Electroluminescence sample holder available (SCA-8)

Cuvette and Powder Holders

- The sphere is supplied with two cuvette holders (10 mm path length) and two powder ($\text{\O}12 \times 2 \text{ mm}^3$) holders
- The powder holder has two positions, for direct and indirect excitation

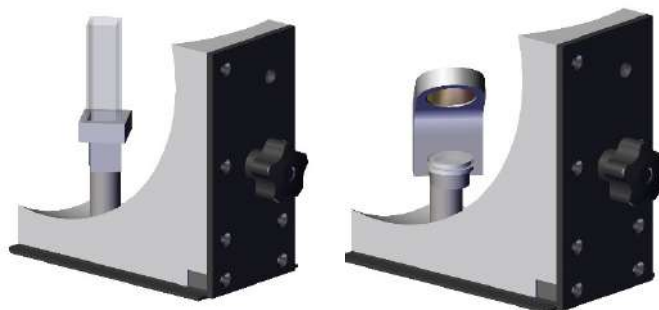

Measurement Examples

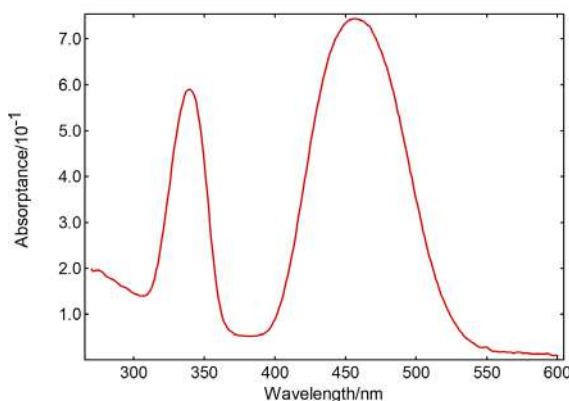
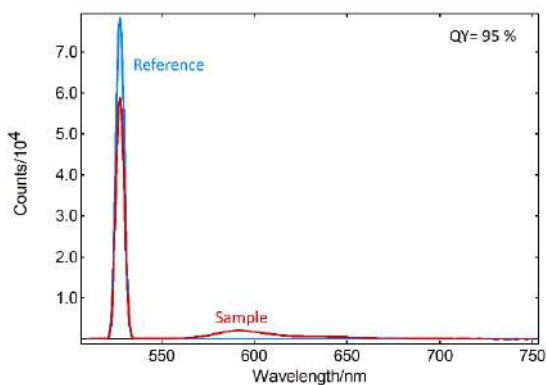

Left: Measurement of absolute fluorescence quantum yield of Rhodamine 101 in ethanol. The scatter of the solvent is shown in blue and the scatter and emission of the Rh 101 in red.
Right: Absorbance spectrum of a Cerium doped YAG phosphor recorded by synchronously scanning the emission and excitation monochromators and measuring the change in reflectance. The absorbance spectrum is then automatically calculated by Fluoracle.

SC-41 Microplate Reader



The SC-41 module is a plate reader for the rapid screening of fluorescent samples. The plate reader is fully controlled by the Fluoracle operating software which allows fully automated excitation, emission and lifetime scans of each well.

Features:

- Automatic spectral and lifetime scans of each well
- Custom well geometries can be defined and saved for later use
- Plates of up to 384 wells can be measured
- Requires black fluorescence plates with opaque bottom

Plate Reader Interface in Fluoracle

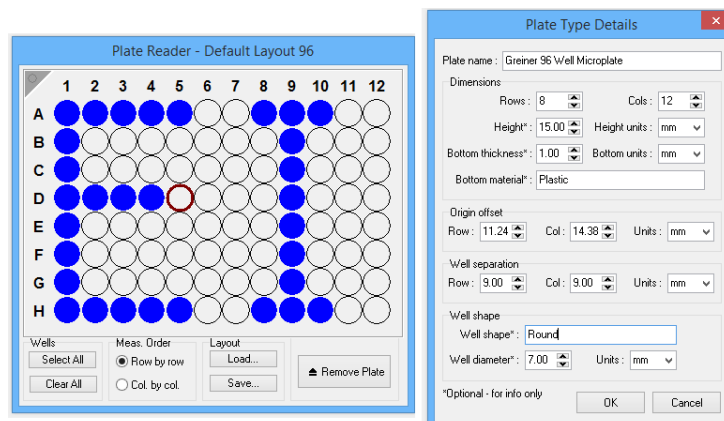

The above figure shows the plate reader user interface in Fluoracle. The wells highlighted in blue are those selected for measurement. New microplate layouts can be easily defined using the wizard on the right and saved for later measurements; allowing custom microplates to be used with the module.

SC-50 Optical Fibre Launcher

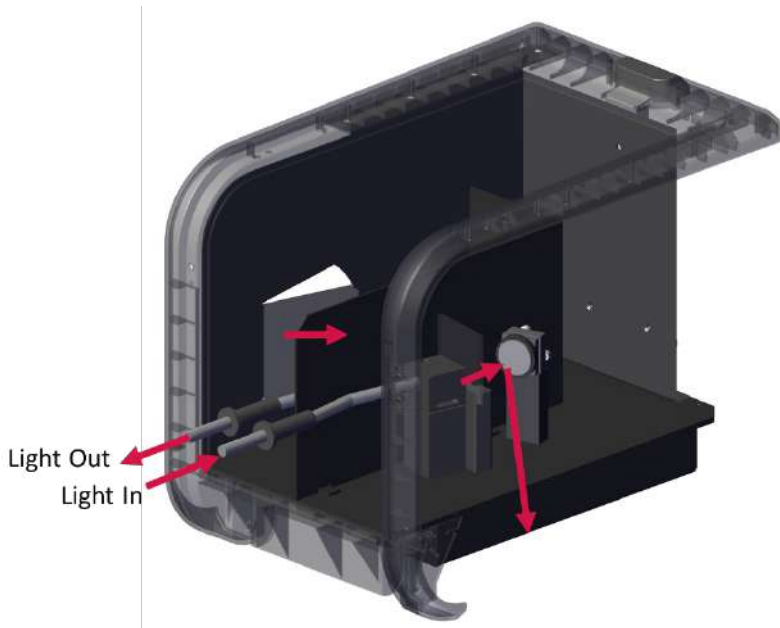

The SC-50 module is used to couple the excitation and emission monochromators of the FS5 to optical fibres. The module is useful for remote sensing of large samples or coupling to a microscope for fluorescence imaging.

Fibre Options:

- Bifurcated fibre bundle (BIF)
- SMA terminated fibres (SMA)
- FC terminated fibres (FC)
- Liquid light guides (LLG)

Measurement Examples

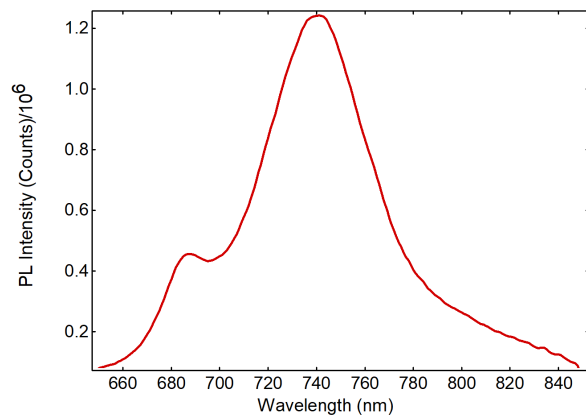
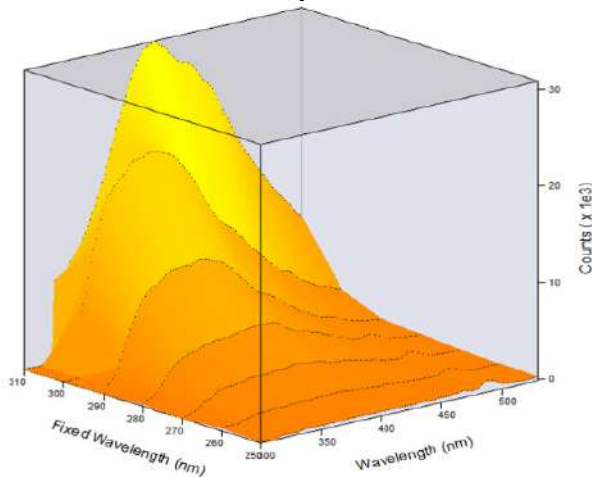

Left: Fluorescence Excitation-Emission Map of human skin measured remotely using the SC-50 with the bifurcated fibre option. **Right:** Emission spectrum of chlorophyll within a leaf, measured in a front face geometry with the bifurcated fibre option.

SC-60 Calibration Module

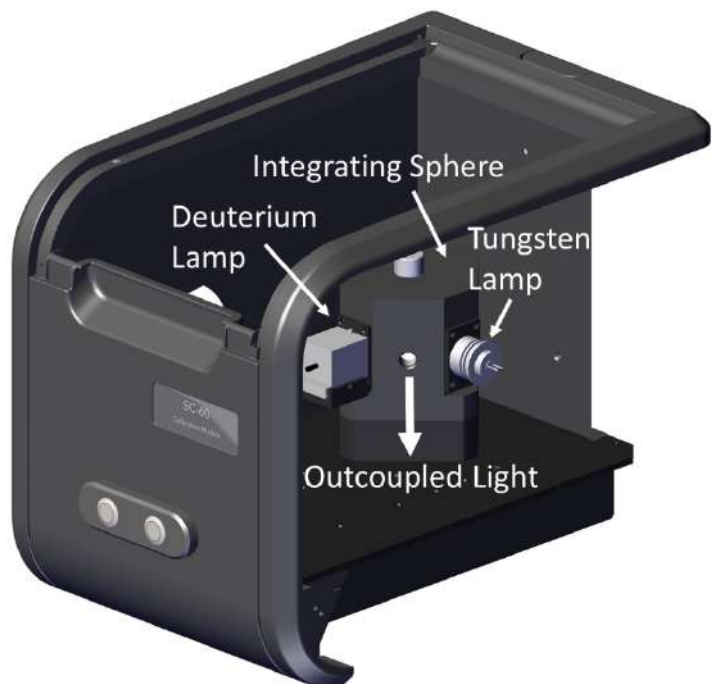

The SC-60 module enables the user to recalibrate emission path of the FS5 by recording new emission correction files. The module contains a deuterium and tungsten lamp with National Physical Laboratory traceable spectra. The lamps are mounted to an integrating sphere (38 mm diameter) for isotropic illumination.

Features:

- Tungsten and deuterium lamps with NPL traceable spectra
- Creation of emission correction files over a 200 nm to 1800 nm wavelength range
- Fluoracle contains a built-in scan type with preset parameters for the optimal measurement of the lamp spectra; followed by a guided procedure for generating the correction files

NPL Traceable Lamp Spectra

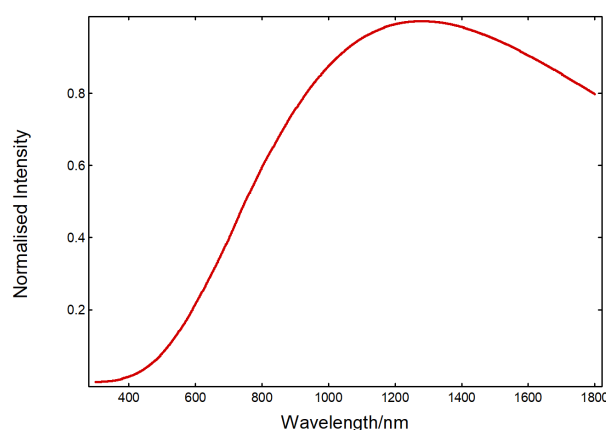
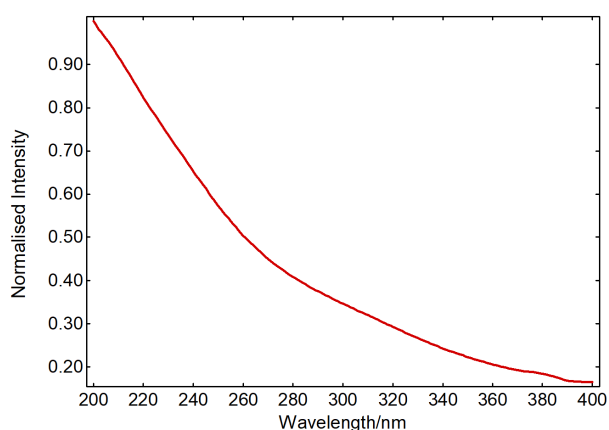

Left: Spectrum of the deuterium lamp which is used to generate the emission correction file over the 200 to 400 nm range. **Right:** Spectrum of the tungsten lamp which is used to generate the emission correction file over the 300 to 1800 nm range.

SC-70 Liquid Nitrogen Dewar



The SC-70 sample module is designed for measuring the photoluminescence of solid samples and frozen solutions at cryogenic temperatures. The sample is held within a quartz tube (4 mm ID) which is immersed in liquid nitrogen. It is a low-cost alternative to traditional cryostats.

Features:

- Sample temperature is 77 K
- Hold time: 1 hour without refilling
- Built-in holders for long pass filters for scattering samples

Measurement Examples

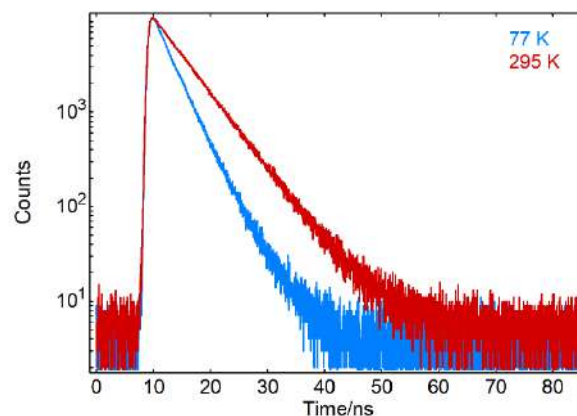
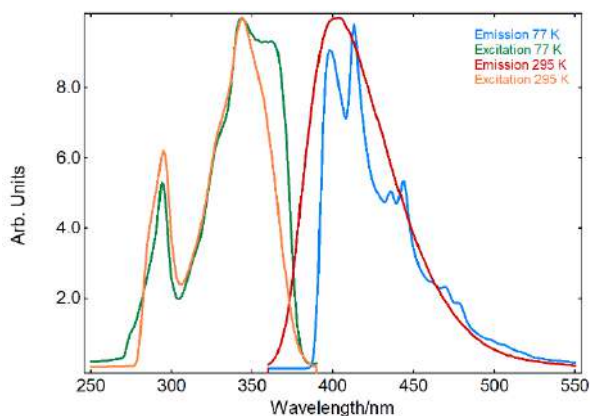

Left: Excitation and emission spectra of a small molecule OLED emitter at 77 K and 295 K.
Right: Photoluminescence decays of the OLED emitter at 77 K and 295 K recorded using time correlated single photon counting (TCSPC).

Specifications

Temperature Range (K)	77
Temperature Stability (K)	± 0.01
Temperature Control	Manual (not recorded by Fluoracle)
Sample Holder Dimensions	4 mm Internal Diameter
Hold time at 77 K	>1 hour (without refill)

SC-80 Cryostat Module



The SC-80 sample module incorporates an Oxford Instruments OptistatDN cryostat for temperature dependent photoluminescence of solutions and solid samples. The temperature is fully controlled by Fluoracle, allowing automatic spectral and lifetime temperature map acquisition and variable temperature batch measurements.

Features:

- Option of vacuum or nitrogen atmosphere
- Cuvette (10 mm), plain (19 x 30 mm²) and optical (19 x 30 mm² with Ø15 mm aperture) sample holders included
- Powder sample holder available (N-SK05-PWD)



Measurement Examples

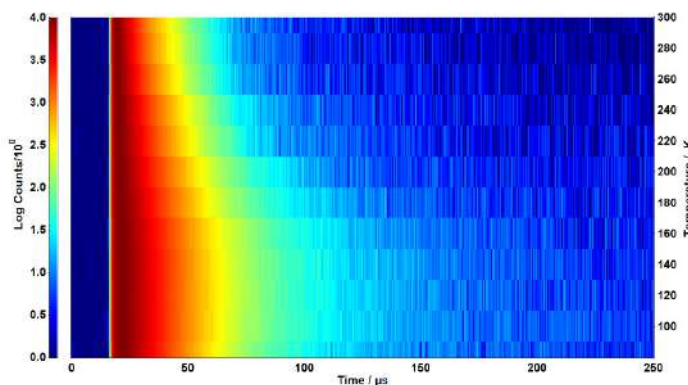
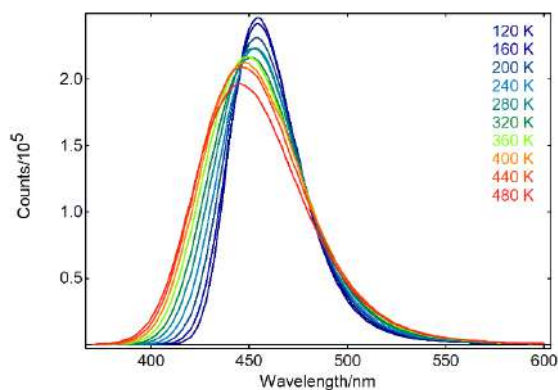

Left: Automatic variable temperature emission scans of the phosphor BaMgAl₁₀O₁₇:Eu, excited at 255 nm. The emission spectrum undergoes a bathochromic shift as the temperature is lowered. **Right:** Automatically acquired lifetime temperature map of Y₂O₃:Er powder. The lifetime decreases with increasing temperature due to thermal quenching.

Specifications

Temperature Range (K)	77 to 500
Temperature Stability (K)	±0.1
Temperature Control	Automatic (controlled and recorded by Fluoracle)
Maximum sample volume	Ø20 mm x 30 mm
Hold time at 77K	15 hours (without refill)

SCA-1 Solid Sample Holder

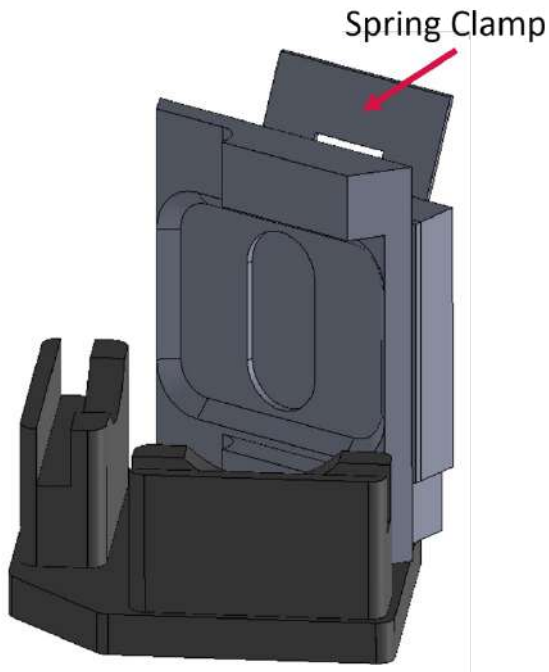

The SCA-1 replaces the standard cuvette holder of the SC-05 sample module. It is designed for photoluminescence and transmittance measurements of solid samples such as thin-films and powders and is an economical alternative to the SC-10 module. If transmittance is not required the SC-10 is recommended, as it offers more accurate and adjustable sample positioning.

Features:

- Photoluminescence and transmittance
- Planar samples are held using spring clamp
Min Sample Dimensions (10 x 10 x 0.5 mm³)
Max Sample Dimensions (40 x 40 x 7 mm³)
- Powder tray and quartz coverslip with an enclosable volume of 10 x 6 x 1 mm³ for photoluminescence measurements of powders and crystallites
- Built-in holders for long pass filters for scattering samples

SCA-2 Solid Sample Holder

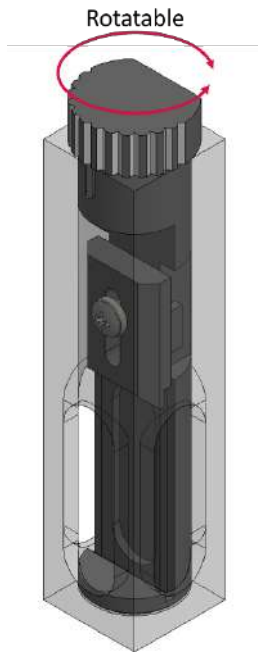

The SCA-2 is an insert for the cuvette holder of the SC-05, SC-20, SC-25 and SC-26 sample modules, which enables the measurement of solid samples. It is useful when quickly changing between solid and solution measurements. For more accurate and adjustable sample positioning, the SC-10 module is recommended.

Features:

- Photoluminescence only
- Can hold powders and small crystallites with an enclosable volume of $15 \times 6 \times 1 \text{ mm}^3$

SCA-3 Syringe Port

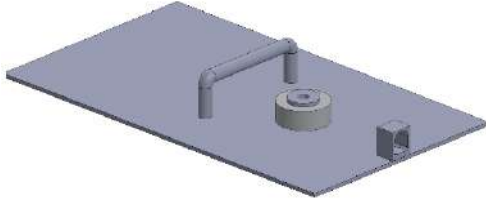

The SCA-3 is an alternative cover for the SC-05, SC-20, SC-24, SC-25 and SC-26 sample modules that incorporates a light tight feed through for syringes and pipettes. It is ideal for in-situ sample mixing and titration during photoluminescence and transmission measurements.

Features:

- Light tight feedthrough for syringes and pipettes with up to 12 mm diameter

SCA-6 Stopped-Flow Accessory



The SCA-6 is a stopped-flow accessory for measuring rapid reaction fluorescence and transmission kinetics with ms time resolution. It is available with a choice of 2 (standard) or 3 (multimixing) injection syringes.

Features:

- Silica cuvette with 4 Spectrosil B observation windows with 2 mm and 10 mm path lengths
- Manual control of injection
- Compatible with the SC-05, SC-20, SC-25 and SC-26 sample modules

Fluorescence quenching of NATA by NBS

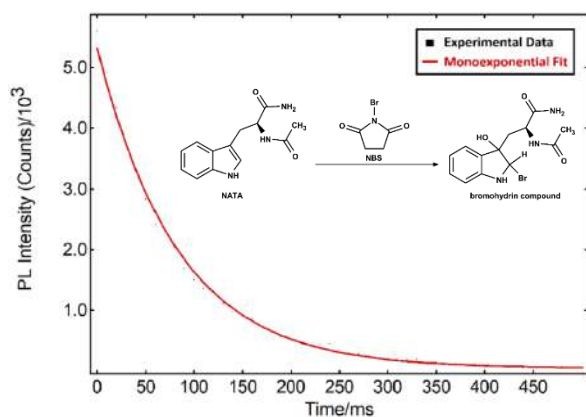

Bleaching of Fe(CN)₆³⁻ by Ascorbic Acid

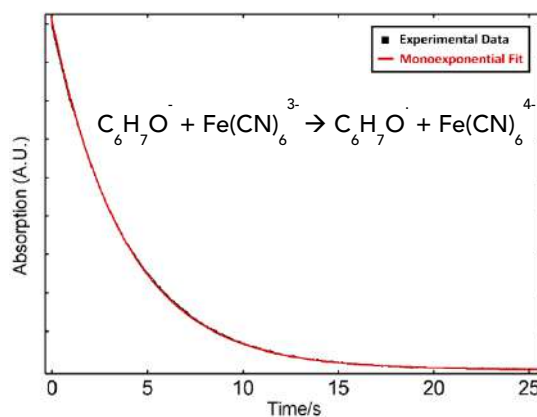

Left: PL kinetic of NATA quenching recorded using the emission detector of the FS5. $\lambda_{ex} = 280$ nm, $\lambda_{em} = 360$ nm. The decay was fit with a single monoexponential using Fluoracle, revealing a first order rate constant of 12 s⁻¹. **Right:** Absorption kinetic of Fe(CN)₆³⁻ bleaching recorded using the transmission detector of the FS5. $\lambda_{ex} = 420$ nm. The decay was fit with a single monoexponential using Fluoracle, revealing a first order rate constant of 0.26 s⁻¹.

Specification

Dead Time (ms)	<10
Time Resolution (ms)	10
Dead Volume (μl)	350 (micro-volume version) or 700 (standard)
Volume per Shot (μl)	100 per reactant
Mixing Ratio	1:1 to 20:1
Chemical Resistance	Very high. Silica and PTFE construction.
Temperature Range (°C)*	5 to 80

*Temperature control is provided by SC-20 or SC-25/26 sample modules. SC-20: the circulating fluid is passed through the coolant jacket surrounding the umbilical to the cuvette, ensuring that the reactants are at the chosen temperature prior to injection and mixing. SC-25/26: reactants are not preheated and heating occurs in the mixing cuvette only.

SCA-7 Solid Sample Holder with Rotation

The SCA-7 replaces the standard cuvette holder of the SC-05 sample module. It is designed for angular dependent photoluminescence and transmission measurements of solid samples and is economical alternative to the SC-10. If angular dependence is not required the SC-10 module is recommended, as it offers more accurate and adjustable sample positioning.

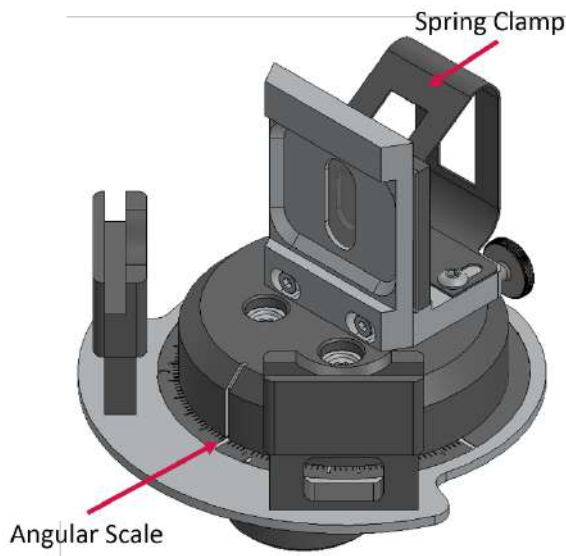

Features:

- Photoluminescence and transmittance
- Graduated angular scale for accurate rotation
- Planar samples held using spring clamp.
Min Sample Dimensions (10 x 10 x 0.5 mm³)
Max Sample Dimensions (40 x 40 x 5 mm³)
- Powder tray and quartz coverslip with an enclosable volume of 10 x 6 x 1 mm³ for photoluminescence measurements of powders and crystallites
- Built-in holders for long pass filters for scattering samples

SCA-8 Electroluminescence Sample Holder for Integrating Sphere

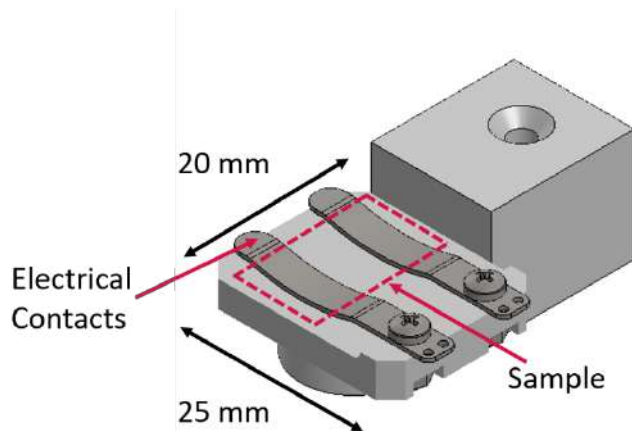







The SCA-8 is an additional sample holder for the SC-30 integrating sphere for electroluminescence measurements



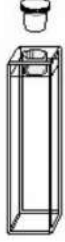

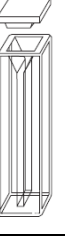
Features:

- 25 mm sample tray with two electrical contacts
- Feedthrough for electrical contact wires



Sample Accessories

C-Q01		<p>PMMA cuvettes for fluorescence 4 clear sides Spectral range 230 – 900 nm 10 mm path length Nominal volume 3.5 mL No cover Box of 100</p>
C-Q02		<p>Quartz cuvette for fluorescence 4 clear sides Spectral range 170 – 2,700 nm 10 mm path length Nominal volume 3.5 mL Simple PTFE cover</p>
C-Q03		<p>Quartz cuvette for fluorescence 4 clear sides Spectral range 170 – 2,700 nm 10 mm path length Nominal volume 3.5 mL Stopper</p>
C-Q04		<p>Quartz cuvette for fluorescence 4 clear sides Spectral range 170 – 2,700 nm 10 mm path length Nominal volume 3.5 mL Screw cap</p>
C-Q05		<p>Quartz microcuvette for fluorescence 4 clear sides Spectral range 170 – 2,700 nm 2 mm and 10 mm path lengths Nominal volume 0.7 mL Simple PTFE cover</p>
C-Q06		<p>Quartz microcuvette for fluorescence 4 clear sides Spectral range 170 – 2,700 nm 2 mm and 10 mm path lengths Nominal volume 0.7 mL Screw cap</p>

Sample Accessories

C-Q07		<p>Demountable quartz cell for powder / viscous samples 2 clear sides Spectral range 170 – 2,700 nm 0.5 mm path length Sample volume fully enclosed</p>
C-Q08		<p>Demountable quartz cell for powder / viscous samples 2 clear sides Spectral range 170 – 2,700 nm 0.5 mm path length Open sample volume</p>
C-Q09		<p>Triangular quartz cuvette for fluorescence 3 clear sides Spectral range 170 – 2,700 nm Recommended to avoid inner filter effect Nominal volume 1.7 mL No cover</p>
C-Q10		<p>Triangular quartz cuvette for fluorescence 3 clear sides Spectral range 170 – 2,700 nm Recommended to avoid inner filter effect Nominal volume 1.7 mL Stopper</p>
C-Q11		<p>Fluorescence cuvette with quartz to glass graded seal Allows permanent sealing of the cuvette 4 clear sides Spectral range 170 – 2,700 nm 10 mm path length Nominal volume 3.5 ml</p>

Sample Accessories

C-Q12		Fluorescence cuvette with demountable reservoir 4 clear sides Spectral range 170 – 2,700 nm 10 mm path length Nominal volume 3.5 ml
C-Q13		Quartz test tube with stopper For liquid samples in Dewar (SC-70) 250 mm long 5 mm outer diameter
C-Q14		Quartz cuvette suitable for use with LNCT/LNCTE cryostats 4 clear sides Dimensions 12 x 12 x 35 mm (shorter than C-Q01 – C-Q06) Non-sealing stopper

- 本カタログに記載されている内容は、改良のため予告無く変更する場合があります。(製品の仕様、性能、価格などはカタログ発行当時のものです)
- 本カタログに記載されている内容の一部または全部を無断で転載することは禁止されております。
- 本カタログに記載されているメーカー名、製品名などは各社の商標または登録商標です。