

ARIS

Compact UV/VIS spectrometer for scientific and industrial applications

Key Features

- Wavelengths between 185 and 1100 nm
- Significantly improved sensitivity
- Superior stray light performance
- Flexibility and reliability for industrial integration



The Aris spectrometer is the next step into the future of embedded spectroscopy. A laboratory-grade instrument that also meets the size, price and reliability requirements for portable and industrial applications.

With its high-throughput optical design, the Aris delivers 2 to 4 times better sensitivity than other spectrometers in this price range. An optimized stray light suppression enables the measurement of larger absorbance values.

The Aris offers an unsurpassed flexibility to adapt the spectrometer to the requirements of a specific application. It is available in six standard wavelength ranges that can be customized using a large choice of available diffraction gratings. The default entrance slit of 20 μm is user-replaceable and can be easily exchanged to obtain better sensitivity. Standard configurations include one of two image sensors (see below) with more choices available on request. The powerful microcontroller performs on-board auto exposure, averaging, buffering and spectrum processing. In addition, it enables the implementation of application-specific spectrum evaluation.

With its proven reliability in rough conditions and compact size, the Aris bridges the gap between laboratory and field spectrometers.

Optics

Optical design	Symmetrical high-throughput Czerny-Turner
Focal length	50 mm
Numerical aperture	0.16 (equivalent area)
Stray light	0.08 % *
Detector lens	Included
Order sorting filter	Included (if required)
Optical interface	SMA connector (other interfaces on request)

* Measured with halogen lamp and long-pass filter

Wavelength ranges and resolutions

The Aris is available in the following standard configurations. Contact us for customized wavelength range.

Configuration	Wavelength range	Resolution (FWHM)	
		typ.	max.
Aris Wide	185 – 1000 nm	1.00	1.20 nm
Aris UV/VIS	185 – 550 nm	0.40	0.60 nm
Aris UV	185 – 420 nm	0.33	0.40 nm
Aris VIS	350 – 840 nm	0.60	0.70 nm
Aris VIS/NIR	510 – 1020 nm	0.80	1.00 nm
Aris Wide NIR	300 – 1100 nm	1.10	1.40 nm

Resolutions are given for the default 20 μm entrance slit and the Toshiba image sensor. A larger entrance slit typically increase both the resolution and the sensitivity proportional to its width. The wavelength accuracy is typically 1/3 of the resolution.

Image Sensors

The Aris is available with a choice of different image sensors:

- The Toshiba TCD1304DG is more affordable, offers slightly better resolution and allows smaller exposure times.
- The Hamamatsu S11639-01 offers better sensitivity (mostly due to lower readout noise) and is much better suited for fast-changing signals and precise external triggering.

	Toshiba TCD1304DG	Hamamatsu S11639-01
Sensor type	CCD	CMOS
Number of pixels	3648	2048
Exposure time range	3 μs – 35 min	54 μs – 35 min
Signal-to-Noise Ratio *	350	600
Dynamic Range **	1900 : 1	6000 : 1
Readout noise ***	35 counts RMS	11 counts RMS
Suitable for fast-changing signals	moderate	very good
Trigger jitter	≤ 1 exposure time	≤ 1 μs

* Maximum Signal-to-Noise Ratio without averaging

** Without averaging, for a single pixel

*** Typical value for a single exposure, scaled to 16 bit

Electronics

Power supply	5 V via USB or Aux connector
Supply voltage range	4.4 – 5.5 V
Power consumption	≤ 70 mA
A/D converter	16 bit, 2 MHz
Non-linearity	< 1 %
Spectrum buffer size	35 spectra (Toshiba TCD1304DG) 63 spectra (Hamamatsu S11639-01)
Auto exposure	On-board during measurement (exposure time and averaging)
Fastest repetition time	4.0 ms (Toshiba TCD1304DG) 2.3 ms (Hamamatsu S11639-01)
Transfer time to host PC via USB (32 bit)	18 ms (Toshiba TCD1304DG) 10 ms (Hamamatsu S11639-01)
Transfer time to host PC via USB (16 bit)	9.5 ms (Toshiba TCD1304DG) 5.5 ms (Hamamatsu S11639-01)
On-board processing	Averaging, buffering and spectrum processing (offset, non-linearity, dark and reference spectrum)
Digital interfaces	USB 2.0 full speed, UART On request: SPI, I ² C
I/O connections	Trigger in, Trigger out, Analog in, Analog out. On request: programmable I/O pins (GPIO), Pulse generator for flash lamps
Connectors	USB Type-C 16-pin Aux connector (IDC)

Absolute maximum ratings

	Minimum	Maximum (power on)	Maximum (power off)
Supply voltage	-0.3 V	5.5 V	
Analog input pins	-0.3 V	4.0 V	3.6 V
Digital input pins	-0.3 V	6.0 V	3.6 V
Output pins	do not apply any voltage		
Temperature	-40 °C	70 °C	70 °C

Technical Drawing

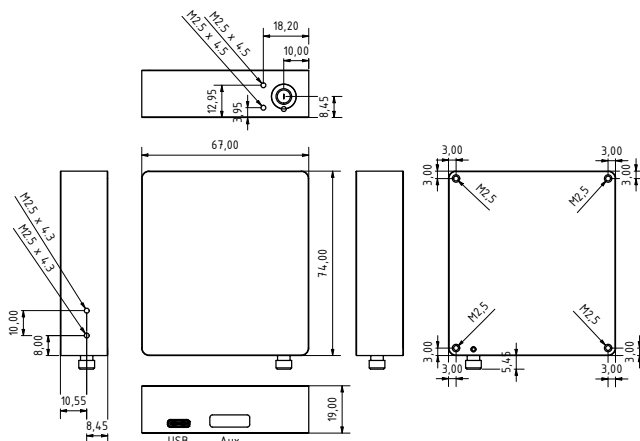

All information is subject to change. The most recent version of this datasheet can be found on our website.

Version 1.3.0 - 2024-01-26

Mechanics and environmental conditions

Dimensions	67.0 × 74.0 × 19.0 mm *
Weight	122 g
Storage temperature	-40 to 70 °C
Operating temperature	-20 to 60 °C
Humidity	0 to 90 % non-condensing

* Without optical interface, see technical drawing below.

Included accessories

- USB cable
- USB memory stick with software and documentation
- Quick start guide
- Calibration and test report

Optional accessories

- Larger entrance slits (user-replaceable)
Available slit sizes: 20, 50, 75, 100, 150, 200, 300 μm
- Fiber-optical patch cables
- Cosine corrector
- SMA collimator
- Direct-attach collimator

Custom options

- Custom wavelength ranges and blaze wavelengths
- Different image sensors
- Additional optical filters
- Application-specific processing and evaluation

Included software

- Application software (Windows 7 and later)
- Software Development Kit (SDK) with Demo code, drivers and protocol documentation

Compliance

The Aris complies with the relevant EU regulations and standards concerning electromagnetic compatibility (2014/30/EU), RoHS (Restriction of Hazardous Substances) SVHC (Substances Of Very High Concern) as well as the U.S. Congo Conflict Minerals Act. Details can be found in the user manual.

Ordering Information

Part number: ARIS-AAA-BBB-CC-DDD

AAA: Start wavelength in nm

BBB: End wavelength in nm

CC: Entrance slit width in μm

DDD: Image sensor: TCD = Toshiba, S11 = Hamamatsu

Contact

Avenir Photonics GmbH & Co. KG

Franz-Mayer-Str. 1, 93053 Regensburg
Germany

Phone: +49 941 462972-80

sales@avenirphotonics.com

support@avenirphotonics.com

www.avenirphotonics.com

Avenir
PHOTONICS



超高真空・極低温走査型プローブ顕微鏡
高速分光測定装置、クライオスタット



Nd:YAGレーザー、Ti:Sレーザー
OPOLレーザー

- 本カタログに記載されている内容は、改良のため予告無く変更する場合があります。（製品の仕様、性能、価格などはカタログ発行当時のものです）
- 本カタログに記載されている内容の一部または全部を無断で転載することは禁止されております。
- 本カタログに記載されているメーカー名、製品名などは各社の商標または登録商標です。